

# UM10510

120 V (AC) 17 W dimmable demo board using the SSL2103

Rev. 1 — 16 January 2012

User manual

## Document information

Info	Content
<b>Keywords</b>	SSL2103, AC mains supply, dimmable LED driver, AC/DC conversion
<b>Abstract</b>	This user manual describes a demo board for evaluating an AC mains LED driver with a dimmer for 17 W, PAR38 LEDs using the SSL2103. It also describes key features and connections to aid the design of LED drivers for typical applications.



## Revision history

Rev	Date	Description
v.1	20120116	first issue

## Contact information

For more information, please visit: <http://www.nxp.com>

For sales office addresses, please send an email to: [salesaddresses@nxp.com](mailto:salesaddresses@nxp.com)

## 1. Introduction

### WARNING

#### Lethal voltage and fire ignition hazard

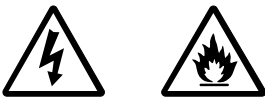

The non-insulated high voltages that are present when operating this product, constitute a risk of electric shock, personal injury, death and/or ignition of fire.

This product is intended for evaluation purposes only. It shall be operated in a designated test area by personnel qualified according to local requirements and labor laws to work with non-insulated mains voltages and high-voltage circuits. This product shall never be operated unattended.

This User manual describes a demonstration (demo) board for evaluating an AC mains LED driver with a dimmer for 17 W, PAR38 LEDs using the SSL2103. It describes key features and connections to aid the design of LED drivers for typical applications.

The demo board operates from an AC mains voltage of 120 V (AC) at 60 Hz. The resulting design is a trade-off between high-power factor, efficiency and dimmer compatibility, combined with high output stability and ElectroMagnetic Compatibility (EMC) compliance.

## 2. Safety Warning

The demo board is powered by AC mains voltage. Avoid touching the board when power is applied. An isolated housing is obligatory when used in uncontrolled, non-laboratory environments. The secondary circuit with LED connection has galvanic isolation, however this isolation is not in accordance with any standard and has not been thoroughly tested. Always provide galvanic isolation of the mains phase using a variable transformer. The following symbols identify isolated and non-isolated devices.

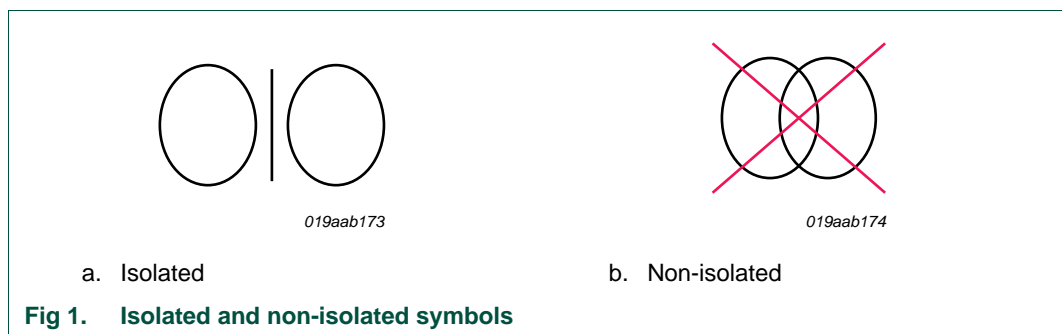

### 3. Specification

**Table 1. Demo board specification**

Parameter	Value	Comment
AC line input voltage	105 V (AC) to 135 V (AC), 60 Hz	120 V (AC) model
Output voltage (LED voltage)	17 V (DC) to 33 V (DC)	
Output voltage protection	33 V (DC)	
Output current (LED current)	500 mA typical	
Input voltage and load current dependency	-5 % to +5 %, input voltage from 210 V (AC) to 250 V (AC)	
Output voltage and load current dependency	-10 % to +10 %, output voltage from 19 V (DC) to 30 V (DC)	
Temperature stability	-3 % to +3 % from -20 °C to 100 °C	
Current ripple	±15 % at 550 mA	typical value
Maximum output power (LED power)	19 W	depends on load
Efficiency	78 % to 82 %	at $T_{amb} = 25\text{ °C}$
Power factor	>0.93	input voltage 120 V (AC)
Switching frequency	40 kHz to 60 kHz	input voltage 120 V (AC)
Dimming range	100 % to 0 %	for triac dimmer
Board dimensions	82 mm × 62 mm × 35 mm	LXBXH
Operating temperature	0 °C to 105 °C	
EMC Compliance	FCC15 and IEC 61000-3-2 pre-compliant EN 55015 and IEC 61000-3-2 pre-compliant	

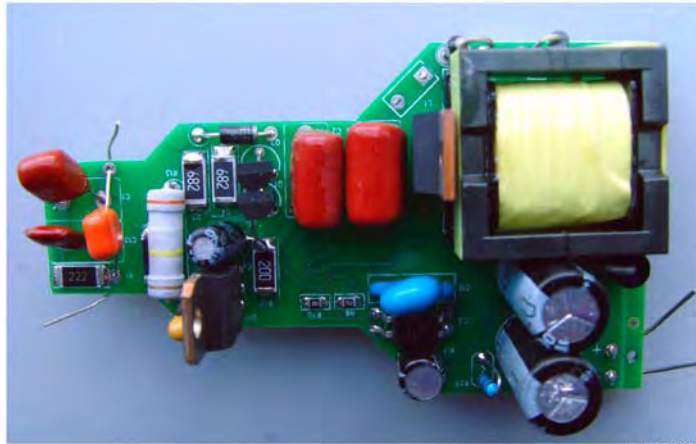

aaa-001885

a. Top view.

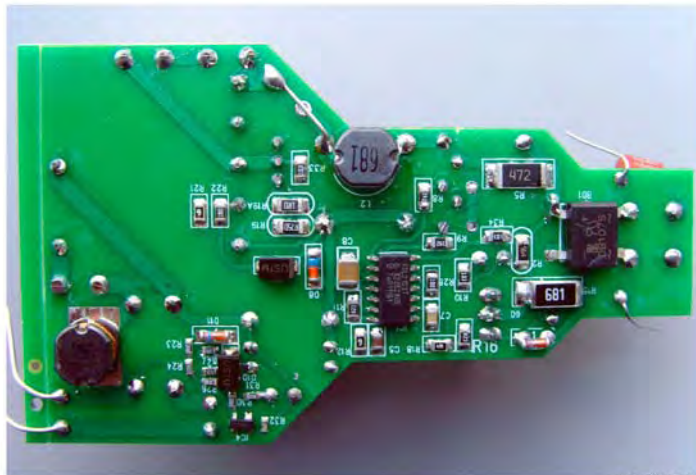

aaa-001886

b. Bottom view

Fig 2. 17 W PAR38 LED demo board

## 4. Demo board connections

The demo board is optimized for an AC mains source of 120 V (60 Hz). It is designed to work with multiple high-power LEDs having a total working voltage of between 18 V and 33 V. The output current is set to 600 mA at typical load. The output voltage is limited to 33 V.

When attaching an LED load to an operational board (hot plugging) an inrush peak current occurs due to the discharge of output capacitors C9 and C10. Frequent discharges can damage or cause deterioration the LEDs.

**Remark:** Mount the board in a shielded or isolated box for demonstration purposes.

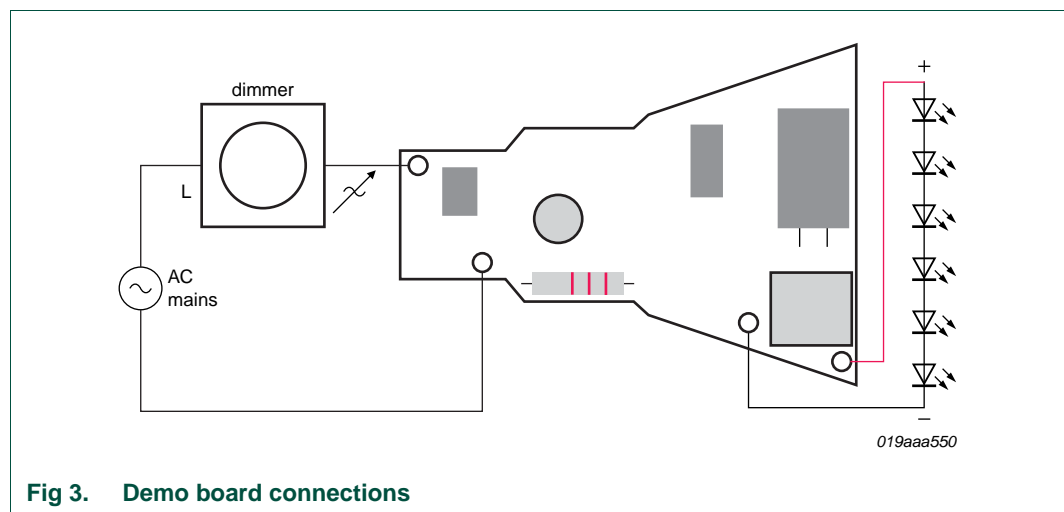

**Fig 3. Demo board connections**

Place a galvanic isolated transformer between the AC source and the demo board, if one is used. Connect a series of between 5 and 10 LEDs to the output as shown in [Figure 3](#).

## 5. Dimmers

NXP Semiconductors has tested the performance of several triac-based dimmers having different specifications. The range of dimmers which have been tested with the demo board are given in [Table 2](#).

**Table 2. Tested dimmers**

*An incandescent lamp is used as load.*

Manufacturer	Type	AC voltage (V)	Power range (W)	Low dim level (%)
Lutron	TG-600PH-WH	120	600	0
Leviton	L12-6641-W	120	600	0
Leviton	L02-700-W	120	600	0
Leviton	6602-IW	120	600	0
Leviton	6683 W	120	600	0
Leviton	R12-6631-LW	120	600	0
Cooper	6001	120	600	0
Lutron	S-600PH	120	600	0
GE	18019	120	600	0
GE	18025	120	600	0
GE	52129	120	600	0

## 6. Functional description

Refer to [Figure 4 “Demo board 120 V \(AC\) schematic” on page 12](#). The AC mains LED driver IC SSL2103 controls and drives a flyback converter circuit and ensures correct dimmer operation. The IC has three integrated high-voltage switches, one of which, located between pins DRAIN and SOURCE, controls flyback input power. When the switch opens, current flows and it is stored as energy in transformer TX1. The current is interrupted when either:

- the duty factor exceeds the 75 % maximum level set using the PWMLIMIT pin
- the voltage on the SOURCE pin exceeds 0.5 V

In the next cycle, the energy stored in the transformer discharges via D6 to output capacitors C9 and C10. The load absorbs the energy. The external RC components connected to pins RC and RC2 control the internal oscillator timing. These external components set the flyback converter frequency. The upper and lower frequency values are set using the BRIGHTNESS pin. The ratio between R11 and R12 sets flyback converter frequency range.

The two other switches in the IC are called weak-bleeder (pin WB\_DRV) and strong-bleeder (pin SB\_DRV). When the voltage on these pins is below a certain value, typically 52 V, the strong-bleeder switches on. A path is provided for the load current to the dimmer during zero voltage crossing. The dimmer timer is reset. When the voltage on the pins is above 52 V and the voltage on pin ISENSE  $> -100$  mV, transistor Q3 switches the weak-bleeder on. The weak-bleeder supplies a boosted (hold) current to the dimmer to maintain stable latching when the flyback converter draws insufficient current.

The demo board is optimized to work at a power factor above 0.9. The flyback converter operates during the MOSFET on-time. Capacitors C9 and C10 buffer the flyback converter output power. This configuration gives the circuit a resistive input current behavior in undimmed mode.

In dimmed mode, the dimmer latch and hold current must be maintained. In addition, add damper to reduce the inrush current and dissipate the electric power stored in the dimmer LC filter.

A serial resistor is used as a damper at power ranges of less than 10 W. However, a serial resistor is inefficient at higher power ranges. The inefficiency is due to the significant voltage drop and dissipation that occurs from the supply current to the flyback converter.

The Darlington transistor Q4 provides the necessary high gain. Q4 is saturated while its base voltage is higher than the emitter voltage plus the base-emitter voltage ( $V_{BE}$ ). The voltage across emitter resistor R14 increases with the current. When the emitter voltage rises above the threshold, Q4 stops saturation, turns off and R15 limits the current. Choose the values of D9 and R13 with care to ensure consistent operation. A Darlington transistor provides the necessary high current gain. This modification changes the specifications of efficiency and power factor.

A combination of serial resistance and a parallel damper is chosen. The serial resistance comprises R14, R15 and R17. The parallel group damper comprises C1, C13 and R1 in parallel with C8 and R7 for optional fine-tuning. To improve efficiency, the major serial damping is activated only when there is a peak inrush current (active inrush current



limiter). In normal operation, the Darlington transistor Q4 conducts, bypassing R15 and lowering ohmic losses. When a high inrush current is detected, Q4 starts to clip at its maximum current of 500 mA.

The flyback converter input circuit must have a filter that is partially capacitive. C2, L2, C3, C13 and L1 form the filter that blocks most of the disturbance caused by the flyback converter input current. The drawback of this filter is a reduced power factor due to the capacitive load. A lower flyback converter power relative to the capacitive value of this filter/buffer reduces the power factor. With the 120 V (AC) design using 330 nF capacitors, a minimum power factor of 0.98 is achieved.

The demo board has a feedback loop to limit the output current. The feedback loop senses the LED current through sense resistor R25, and current mirror circuit with IC4. The current level can be set using R27 and R29. The same feedback loop is also used for overvoltage protection. If the LED voltage exceeds 33 V, a current starts to flow through R23 and D11. The current through the optocoupler IC3 forces pins PWMLIMIT and BRIGHTNESS LOW. At a value below 400 mV, the MOSFET on-time is zero.

The feedback loop has a proportional action only. The gain is critical because of phase shift caused by the flyback converter.

The relationship between pin PWMLIMIT and the output current is quadratic in nature. The resulting output current spread is acceptable for most LED applications. If higher demands are placed on LED current spread, a secondary regulation circuit in combination with an added pure current action control is advisable.

The dimming range is detected by sensing the average rectified voltage. R2 and R10 form a voltage divider, and C4 filters the resulting signal. The flyback converter sets its duty factor and converter frequency accordingly.

## 7. System optimization

The modifications described in this section can be applied to achieve customer application specifications.

### 7.1 Changing output voltage and LED current

One of the major advantages of a flyback converter over other topologies is its suitability for driving different output voltages. In essence, changing the winding ratio while maintaining the value of the primary inductance shifts the output working voltage accordingly. Part of the efficiency of the driver is linked to the output voltage. A lower output voltage increases the transformation ratio and cause higher secondary losses. In practice, mains dimmable flyback converters have an efficiency of:

- 85 % for higher output power and voltage such as 60 V
- down to 60 % for lower output power and voltage such as 1 W and 3 V respectively

At lower voltages, synchronous rectification is advisable to reduce losses after high current is rectified. NXP Semiconductors TEA1761 and TEA1791 synchronous rectification controllers are ideal for this purpose. Calculations for transformer properties and peak current are described in detail in application note *AN10754, SSL2101 and SSL2103 dimmable mains LED driver*.

### 7.2 Changing the output ripple current

The LED voltage, the LED dynamic resistance and the output capacitor determine the output ripple current. While the values of C9 and C10 are chosen to optimize capacitor size with light output. A ripple of  $\pm 15\%$  results in an expected deterioration of LED brightness of less than 1 %<sup>1</sup>.

The size of the buffer capacitor can be determined from [Equation 1](#).

$$\left(C10 + C9 = \frac{I_{led}}{\Delta I}\right) \times \frac{1}{6 \times f_{net} \times R_{dyn}} \quad (1)$$

**Example:**

A  $\pm 5\%$  ripple current, a 50 Hz AC mains frequency and a  $0.6 \Omega$  dynamic resistance, results in a combined C9 + C10 value of  $\frac{20}{300 \times 0.6} = 111 \text{ mF}$ .

A ripple current of 25 % and a dynamic resistance of  $6 \Omega$ , results in a value for C9 + C10 of  $\frac{4}{(300 \times 6)} = 2200 \mu\text{F}$ .

Using a series of LEDs, the dynamic resistance of each LED can be added to the total dynamic resistance.

1. M. Weiland 28-07-2006

### 7.3 Adapting to high-power reverse phase transistor dimmers

Reverse phase (transistor) dimmers differ in two ways that can be beneficial:

- Due to the negative phase, there is no inrush current when the dimmer triggers. Using triac dimmers, there is a sudden voltage difference over the input, resulting in a steep charge of the input capacitors. The resulting peak current results in higher damper dissipation. Using transistor dimmers, the steep charge is missing. The input capacitors are less stressed and the input circuit is less prone to audible noise.
- Transistor dimmers contain active circuitry that requires a load charge while the dimmer is open. To avoid internal dimmer losses, the dimensioning of the internal supply voltage generation circuit is critical. This means that the remaining voltage drop across the lamp must be low enough to allow this charge to be reached. The minimum load to achieve such a low voltage drop results in inefficient operation at low output power levels. The cause of which is that most of the energy is wasted driving the dimmer instead of used to producing light.

The weak-bleeder resistor values of R3 and R4 are chosen to ensure that any losses are within acceptable limits. These losses only occur in dimmed mode at the end of the phase. The voltage drop in some transistor dimmers is not sufficient for full control of the dimming range. The SSL2103 senses the dimming range by taking the average rectified voltage as input. To compensate for the reduced voltage difference, the voltage detection can be made more sensitive by placing a Zener diode in series with R2. The dimming curve is steeper and shifted when using triac dimmers because of increased sensitivity.

### 7.4 Changing the output current

The output current can be set initially by varying the values of R29 and R27. The power section and transformer train can withstand output currents up to 500 mA, but losses increase at higher current levels. Resistors R19/R19A limit the primary peak current and consequently the maximum output power.

8. Demo board schematic

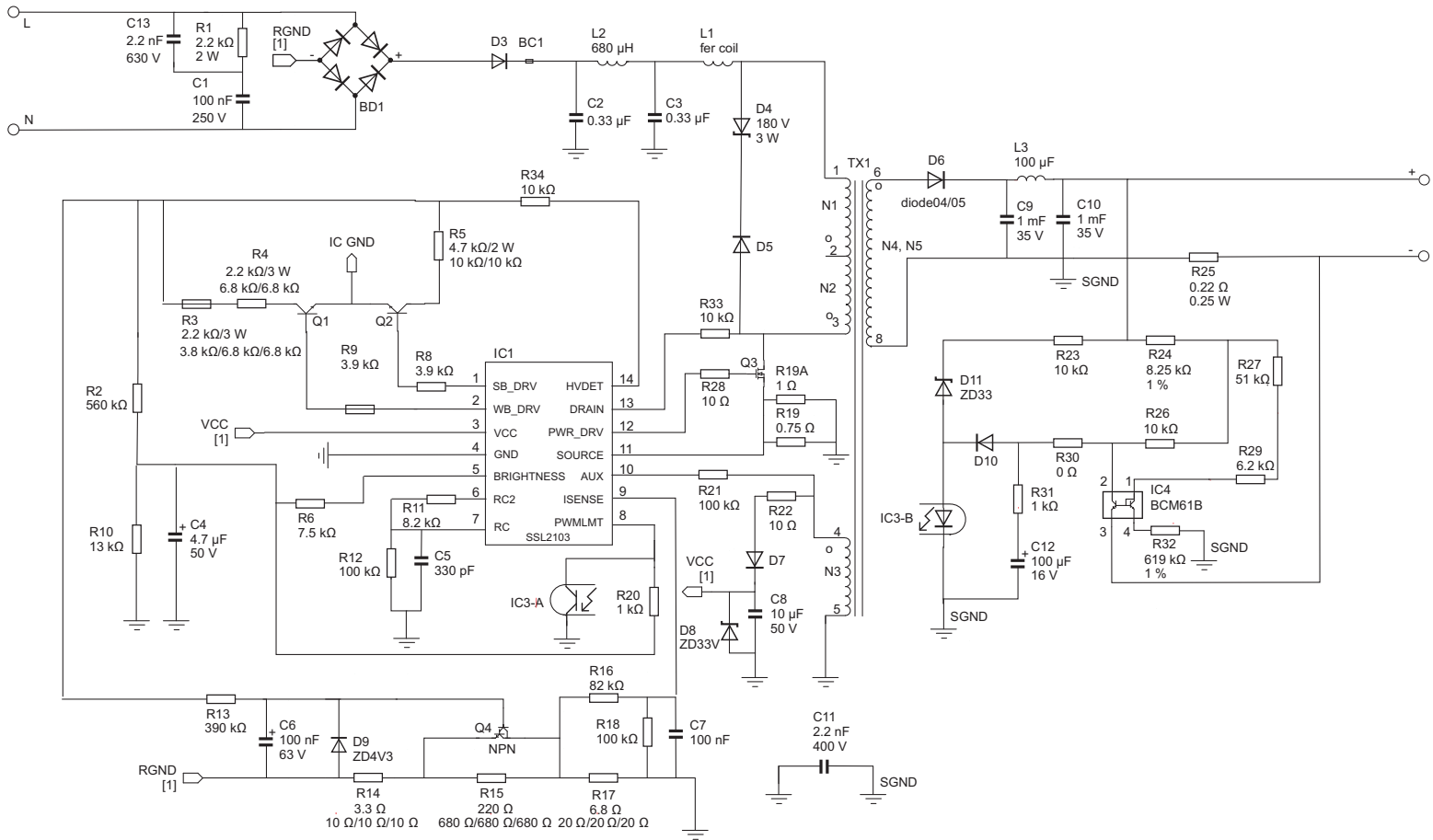

aaa-001834

(1) Optional.

Some resistor values are shown with format x/x/x which represent the values required of resistors connected in parallel.

Fig 4. Demo board 120 V (AC) schematic

## 9. PCB components

**Table 3. Demo board 120 V (AC) components**

Designator	Description	Part identifier	Manufacturer
BD1	rectifier bridge, SMD	DB107S	-
R1	2.2 k $\Omega$ , 2 W, 5 %, 200 V, SMD, 2512	-	-
R2	560 k $\Omega$ , 0.25 W, 1 %, 200 V, SMD, 1206	-	-
R3; R4	2.2 k $\Omega$ , 3 W, 5 %, 400 V, SMD, 2512	-	-
R5	4.7 k $\Omega$ , 2 W, 5 %, 400 V, SMD, 2512	-	-
R6	7.5 k $\Omega$ , 0.125 W, 5 %, SMD, 0805	-	-
R8; R9	3.9 k $\Omega$ ; 0805	-	-
R10	13 k $\Omega$ , 0.125 W, 1 %, SMD, 0805	-	-
R11	8.2 k $\Omega$ , 0.125 W, 1 %, SMD, 0805	-	-
R12; R18; R21	100 k $\Omega$ , 0.125 W, 1 %, SMD, 0805	-	-
R13	390 k $\Omega$ ; 2 W; 5 %; RT3.5MM	-	-
R14	3.3 $\Omega$ , 3 W, 5 %, 400 V, SMD, 2512	-	-
R15	220 $\Omega$ , 2 W, 5 %, 400 V, SMD, 2512	-	-
R16	82 k $\Omega$ , 0.125 W, 1 %, SMD, 0805	-	-
R17	6.8 $\Omega$ , 2 W, 5 %, 400 V, SMD, 2512	-	-
R19	0.75 $\Omega$ , 0.25 W, 1 %, SMD, 1206	-	-
R19A	1 $\Omega$ , SMD, 1206	-	-
R20	1 k $\Omega$ , 0.125 W, 1 %, SMD, 0805	-	-
R22	10 $\Omega$ , 0.125 W, 5 %, SMD, 0805	-	-
R23; R26	10 k $\Omega$ , 0.125 W, 5 %, SMD, 0603	-	-
R24	8.25 k $\Omega$ , 0.125 W, 5 %, SMD, 0603	-	-
R25	0.22 $\Omega$ , 0.25 W, RT3.5MM-2W20	-	-
R27	51 k $\Omega$ , 0.125 W, 1 %, SMD, 0603	-	-
R28	10 $\Omega$ ; SMD, 0805	-	-
R29	6.2 k $\Omega$ , SMD, 0603	-	-
R30	0 $\Omega$ , SMD, 0603	-	-
R31	1 k $\Omega$ , SMD, 0603	-	-
R32	619 $\Omega$ ; 1 %; SMD; 0603	-	-
R33; R34	10 k $\Omega$ , 0805	-	-
C1	100 nF; 250 V; MKT, CM150-5_6X12	-	-
C2, C3	0.1 $\mu$ F; 10 %, 400 V; CM150-5_6X18	-	-
C4	4.7 $\mu$ F, 50 V; CAL04/05	-	-
C5	330 pF; 0805	-	-
C6	100 nF, MKT, 50 V; CAL04/05	-	-
C7	100 nF, 0805	-	-
C8	10 $\mu$ F, 50 V; 1206	-	-
C9; C10	1 mF; 35 V; ECOUT	-	-
C11	2.2 nF, 400 V; C-POLY	-	-
C12	100 $\mu$ F, 16 V; C-POLY	-	-

**Table 3.** Demo board 120 V (AC) components ...continued

Designator	Description	Part identifier	Manufacturer
C13	630 V; CM150-5_6X18	-	-
L1	FERCHOCK; Ferrite Coil	-	-
L2	L-DIP; 680 $\mu$ H	-	-
L3	WECHOCK-2; 100 $\mu$ H	-	-
TX1	EFD25-DIP	-	-
D3	ultra-fast diode; HER107; lead axial	DO-201	-
D4	diode; DIP 180 V; 3 W	-	-
D5; D6	switching diode, DIP2	-	-
D7	switching diode, SO8; SMD	-	-
D8	Zener diode, ZD33V	ZD33V	-
D9	Zener diode, 4.3 V, SMD, SOD80	ZD4V3	-
D10	SOD80	-	-
D11	Zener diode, 33 V, SMD	ZD33	-
Q1; Q2	transistor, PNP, TO-92	-	-
Q3	MOSFET; TO-251	-	-
Q4	transistor, NPN, TO-220	ST901T	-
IC1	controller, SMD, SOW-20, SSL2103	SSL2103	-
IC3	IC04-10/PC	LTV-817B	Lite-On
IC4	dual, NPN, SMD, SOT143, BCM61B	BCM61B	-

## 10. Test results

### 10.1 Input/output stability

**Table 4. Input and output stability test results**

Parameter	Conditions			
$V_{IN}$ AC mains voltage	110	120	130	140
input power (W)	17.016	17.46	17.68	17.817
Power factor	0.989	0.985	0.97	0.96
$V_{LED}$ (V)	28.88	28.955	29.097	29.11
$I_{LED}$ (A)	497	510	515	524
$P_o$	14.159	14.75	14.963	15.232
$\eta$ (%)	83.2	84.4	84.6	85.3

**Table 5. Tested dimmers**

Manufacturer	Part
Lutron	D-600PH-DK
Lutron	S-600PH-WH
Lutron	TT-300NLH-WH
Lutron	LG-600PH-WH
Lutron	TG-600PH-WH
Lutron	DV-603P
Leviton	R52-TB103-1LW
Leviton	C20-6681-IW
Leviton	6631-1LW

## 11. Legal information

### 11.1 Definitions

**Draft** — The document is a draft version only. The content is still under internal review and subject to formal approval, which may result in modifications or additions. NXP Semiconductors does not give any representations or warranties as to the accuracy or completeness of information included herein and shall have no liability for the consequences of use of such information.

### 11.2 Disclaimers

**Limited warranty and liability** — Information in this document is believed to be accurate and reliable. However, NXP Semiconductors does not give any representations or warranties, expressed or implied, as to the accuracy or completeness of such information and shall have no liability for the consequences of use of such information. NXP Semiconductors takes no responsibility for the content in this document if provided by an information source outside of NXP Semiconductors.

In no event shall NXP Semiconductors be liable for any indirect, incidental, punitive, special or consequential damages (including - without limitation - lost profits, lost savings, business interruption, costs related to the removal or replacement of any products or rework charges) whether or not such damages are based on tort (including negligence), warranty, breach of contract or any other legal theory.

Notwithstanding any damages that customer might incur for any reason whatsoever, NXP Semiconductors' aggregate and cumulative liability towards customer for the products described herein shall be limited in accordance with the *Terms and conditions of commercial sale* of NXP Semiconductors.

**Right to make changes** — NXP Semiconductors reserves the right to make changes to information published in this document, including without limitation specifications and product descriptions, at any time and without notice. This document supersedes and replaces all information supplied prior to the publication hereof.

**Suitability for use** — NXP Semiconductors products are not designed, authorized or warranted to be suitable for use in life support, life-critical or safety-critical systems or equipment, nor in applications where failure or malfunction of an NXP Semiconductors product can reasonably be expected to result in personal injury, death or severe property or environmental damage. NXP Semiconductors and its suppliers accept no liability for inclusion and/or use of NXP Semiconductors products in such equipment or applications and therefore such inclusion and/or use is at the customer's own risk.

**Applications** — Applications that are described herein for any of these products are for illustrative purposes only. NXP Semiconductors makes no representation or warranty that such applications will be suitable for the specified use without further testing or modification.

Customers are responsible for the design and operation of their applications and products using NXP Semiconductors products, and NXP Semiconductors accepts no liability for any assistance with applications or customer product design. It is customer's sole responsibility to determine whether the NXP Semiconductors product is suitable and fit for the customer's applications and products planned, as well as for the planned application and use of customer's third party customer(s). Customers should provide appropriate design and operating safeguards to minimize the risks associated with their applications and products.

NXP Semiconductors does not accept any liability related to any default, damage, costs or problem which is based on any weakness or default in the customer's applications or products, or the application or use by customer's third party customer(s). Customer is responsible for doing all necessary testing for the customer's applications and products using NXP Semiconductors products in order to avoid a default of the applications and the products or of the application or use by customer's third party customer(s). NXP does not accept any liability in this respect.

**Export control** — This document as well as the item(s) described herein may be subject to export control regulations. Export might require a prior authorization from competent authorities.

**Evaluation products** — This product is provided on an "as is" and "with all faults" basis for evaluation purposes only. NXP Semiconductors, its affiliates and their suppliers expressly disclaim all warranties, whether express, implied or statutory, including but not limited to the implied warranties of non-infringement, merchantability and fitness for a particular purpose. The entire risk as to the quality, or arising out of the use or performance, of this product remains with customer.

In no event shall NXP Semiconductors, its affiliates or their suppliers be liable to customer for any special, indirect, consequential, punitive or incidental damages (including without limitation damages for loss of business, business interruption, loss of use, loss of data or information, and the like) arising out of the use of or inability to use the product, whether or not based on tort (including negligence), strict liability, breach of contract, breach of warranty or any other theory, even if advised of the possibility of such damages.

Notwithstanding any damages that customer might incur for any reason whatsoever (including without limitation, all damages referenced above and all direct or general damages), the entire liability of NXP Semiconductors, its affiliates and their suppliers and customer's exclusive remedy for all of the foregoing shall be limited to actual damages incurred by customer based on reasonable reliance up to the greater of the amount actually paid by customer for the product or five dollars (US\$5.00). The foregoing limitations, exclusions and disclaimers shall apply to the maximum extent permitted by applicable law, even if any remedy fails of its essential purpose.

### 11.3 Trademarks

Notice: All referenced brands, product names, service names and trademarks are the property of their respective owners.



## 12. Contents

---

<b>1</b>	<b>Introduction</b> .....	<b>3</b>
<b>2</b>	<b>Safety Warning</b> .....	<b>3</b>
<b>3</b>	<b>Specification</b> .....	<b>4</b>
<b>4</b>	<b>Demo board connections</b> .....	<b>6</b>
<b>5</b>	<b>Dimmers</b> .....	<b>7</b>
<b>6</b>	<b>Functional description</b> .....	<b>8</b>
<b>7</b>	<b>System optimization</b> .....	<b>10</b>
7.1	Changing output voltage and LED current . . .	10
7.2	Changing the output ripple current . . . . .	10
7.3	Adapting to high-power reverse phase transistor dimmers .....	11
7.4	Changing the output current . . . . .	11
<b>8</b>	<b>Demo board schematic</b> .....	<b>12</b>
<b>9</b>	<b>PCB components</b> .....	<b>13</b>
<b>10</b>	<b>Test results</b> .....	<b>15</b>
10.1	Input/output stability .....	15
<b>11</b>	<b>Legal information</b> .....	<b>16</b>
11.1	Definitions .....	16
11.2	Disclaimers .....	16
11.3	Trademarks .....	16
<b>12</b>	<b>Contents</b> .....	<b>17</b>

---

Please be aware that important notices concerning this document and the product(s) described herein, have been included in section 'Legal information'.

---

© NXP B.V. 2012.

All rights reserved.

For more information, please visit: <http://www.nxp.com>

For sales office addresses, please send an email to: [salesaddresses@nxp.com](mailto:salesaddresses@nxp.com)

Date of release: 16 January 2012

Document identifier: UM10510